

UNCONTROLLED DOCUMENT

PART NUMBER
SSL-LX5093SRC/X

REV.
D

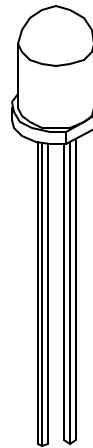
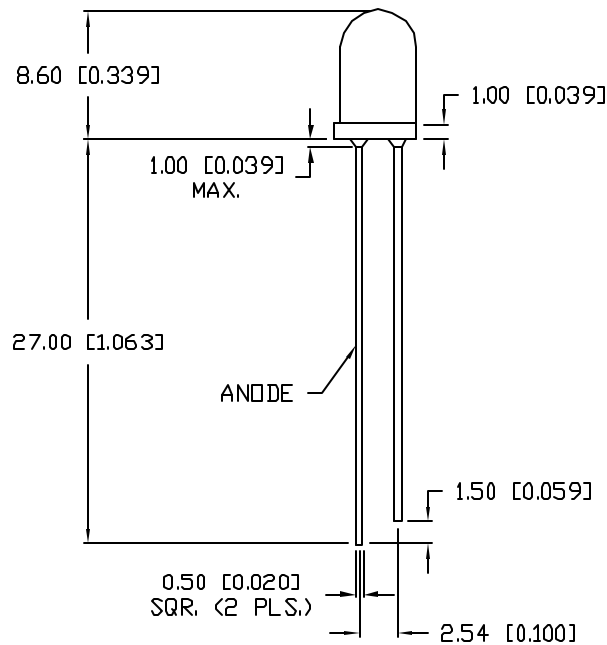
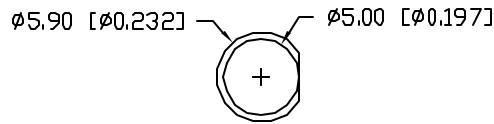

REV.	E.C.N. NUMBER AND REVISION COMMENTS	DATE
A	UPDATED SPECS.	1.5.95
B	E.C.N. #10251.	9.30.96
C	E.C.N. #10BRDR. & REDRAWN IN 3D.	5.31.01
D	E.C.N. #10788.	9.13.01

ELECTRO-OPTICAL CHARACTERISTICS $T_A=25^\circ\text{C}$ $I_f=20\text{mA}$

PARAMETER	MIN	TYP	MAX	UNITS	TEST COND
PEAK WAVELENGTH		660		nm	
FORWARD VOLTAGE		1.7	2.2	V_f	
REVERSE VOLTAGE	4.0			V_r	$I_f=100\mu\text{A}$
AXIAL INTENSITY /DU	1000	1200		mcd	$I_f=20\text{mA}$
/DV	1300	1500		mcd	$I_f=20\text{mA}$
/DW	1600	1800		mcd	$I_f=20\text{mA}$
/E	2000	2800		mcd	$I_f=20\text{mA}$
/F	3500	4000		mcd	$I_f=20\text{mA}$
VIEWING ANGLE		30		2x theta	
EMITTED COLOR:	RED				
EPOXY LENS FINISH:	WATER CLEAR				

LIMITS OF SAFE OPERATION AT 25°C

PARAMETER	MAX	UNITS
PEAK FORWARD CURRENT*	150	mA
STEADY CURRENT	30	mA
POWER DISSIPATION	100	mW
DERATE FROM 25°C	-1.2	mW/ $^\circ\text{C}$
OPERATING, STORAGE TEMP.	-40 TO +85	$^\circ\text{C}$
SOLDERING TEMP.	+260	$^\circ\text{C}$
2.0mm FROM BODY		3 SEC. MAX

* $t < 10\mu\text{s}$

REPLACES PART #: SSL-LX5093SRC(/B-/E)

*UNLESS OTHERWISE SPECIFIED TOLERANCES PER DECIMAL PRECISION ARE: X= ± 1 (± 0.039), XX= ± 0.5 (± 0.020), XXX= ± 0.25 (± 0.010), XXXX= ± 0.127 (± 0.005). LEAD SIZE= ± 0.05 (± 0.002), LEAD LENGTH= ± 0.75 (± 0.030), MIN=^{+0.00}/_{-0.00} DECIMAL PRECISION, MAX.=^{+0.00}/_{-0.00} DECIMAL PRECISION

UNCONTROLLED DOCUMENT

REV.	PART NUMBER
D	SSL-LX5093SRC/X

CONFIDENTIAL INFORMATION
THE INFORMATION CONTAINED IN THIS DOCUMENT IS THE PROPERTY OF LUMEX INC. EXCEPT AS SPECIFICALLY AUTHORIZED IN WRITING BY LUMEX INC., THE HOLDER OF THIS DOCUMENT SHALL KEEP ALL INFORMATION CONTAINED HEREIN CONFIDENTIAL AND SHALL PROTECT SAME IN WHOLE OR IN PART FROM DISCLOSURE AND DISSEMINATION TO ALL THIRD PARTIES.



290 E. HELEN ROAD
PALATINE, IL 60067-6976
PHONE: +1.847.359.2790
US WEB: www.lumex.com
TW WEB: www.lumex.com.tw

T-5mm (T-1 3/4) 660nm SUPER RED LED,
WATER CLEAR LENS.

RELIABILITY NOTE
OUR MANY YEARS OF EXPERIENCE DATA ACCUMULATION INDICATE THAT SOLDER HEAT IS A MAJOR CAUSE OF EARLY AND FUTURE FAILURE. PLEASE PAY ATTENTION TO YOUR SOLDERING PROCESS.

DRAWN BY:	CHECKED BY:	APPROVED BY:	DATE:
BC			2.9.93
			PAGE: 1 OF 1
			SCALE: N/A